

Minibagger Case CX18B

Technische Daten Minibagger CX18B

Max. Grabtiefe	2,40 m	Transporthöhe	2,35 m
Max. Reichweite	3,99 m	Transportlänge	3,61 m
Max. Schütthöhe	2,60 m	Transportbreite	0,99 m
Schaufelaufnahme	MS 01	Eigengewicht	1780kg

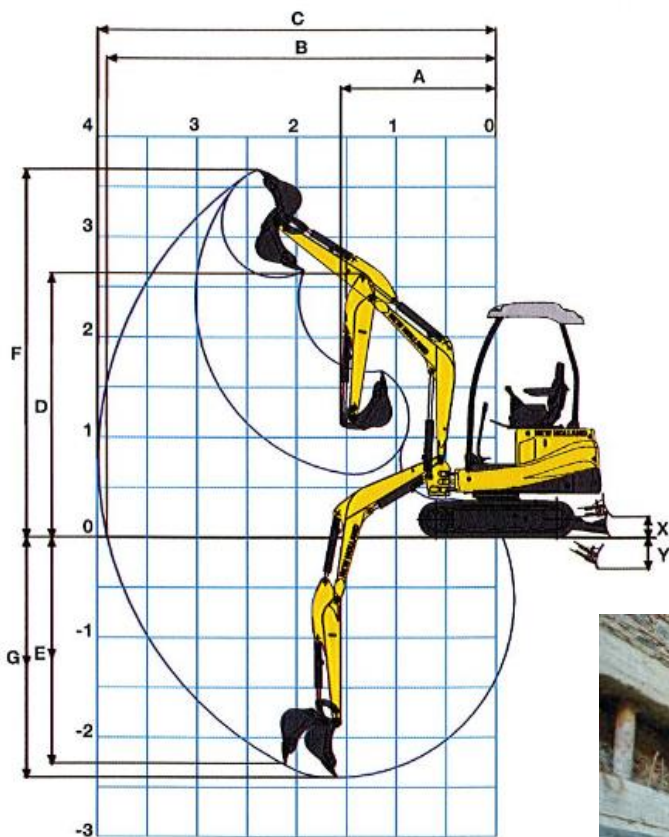

Gummikette

-BLESER G m b H
MIETSTATION

Arbeitsbühnen · Baumaschinen

Danziger Straße 5 · 56564 Neuwied
Tel. 0 26 31 / 35 61 10 · Fax 0 26 31 / 35 61 12
blesermietstation.de · info@blesermietstation.de

